

SAFETY AND HANDLING GUIDELINES FOR ELECTROCHEM LITHIUM BATTERIES



Electrochem Commercial Power, division of Greatbatch Ltd.

9645 Wehrle Drive, Clarence, NY 14031 Tel: 716-759-5800 Fax: 716-759-2562

100 Energy Drive, Canton, MA 02021 Tel: 781-575-0800 Fax: 781-575-1545

webpage: www.electrochempower.com

e-mail: cos@electrochempower.com

DISCLAIMER: The information contained in this document is for reference only. It should not be used in place of appropriate Federal, State, or local regulations or other legal requirements. Greatbatch and/or Electrochem are not responsible for updating its contents hereof, or for any incident that occurs due to misuse or abuse of lithium cells and batteries.

George Murray	<u>Plant Manager-Canton</u>	<u>Date:</u> 11/23/2005
Robert Yetman	<u>Quality Manager</u>	<u>Date:</u> 11/22/2005
Arden Johnson	<u>R&D Manager</u>	<u>Date:</u> 11/17/2005
Matthew Heafey	<u>Safety Technician</u>	<u>Date:</u> 11/22/2005
Kathy O'Shei	<u>Safety Director</u>	<u>Date:</u> 11/28/2005

Index

<u>Section</u>	<u>Title</u>	<u>Page</u>
1.0	INTRODUCTION	3
2.0	SAFE HANDLING GUIDELINES	5
2.1	RECEIVING INSPECTION AND STORAGE OF CELLS	5
2.2	CELL STORAGE	7
2.3	HANDLING PROCEDURES DURING PRODUCT ASSEMBLY	7
2.4	PACKAGING FOR SHIPMENT	9
3.0	BATTERY PACK ASSEMBLY	12
3.1	CELL SELECTION	12
3.2	BATTERY PACK DESIGN	13
3.3	BATTERY FABRICATION	16
4.0	HANDLING UNDER ADVERSE CONDITIONS	18
4.1	PROCEDURES FOR HANDLING A HOT CELL	18
4.1.1	Minimum Equipment Required	18
4.1.2	Procedure	19
4.2	PROCEDURE FOR HANDLING CELLS THAT HAVE VENTED	19
4.2.1	Minimum Equipment Required	20
4.2.2	Procedure	21
4.2.3	First Aid Procedures in Case of Contact with Electrolyte	22
4.3	PROCEDURE FOR CELLS THAT HAVE EXPLODED	22
4.3.1	Minimum Equipment Required	22
4.3.2	Procedure	23
4.3.3	First Aid Procedures in Case of Contact with electrolyte	24
4.4	FIRES INVOLVING LITHIUM BATTERIES	24
4.4.1	Minimum Equipment Required	25
4.4.2	Procedure	25
4.4.2.1	Initial Response	25
4.4.2.2	Clean-up	27
4.4.2.3	First Aid Procedures in Case of Contact with Electrolyte	27
4.5	Regulatory Considerations	27

**SAFETY AND HANDLING GUIDELINES FOR
ELECTROCHEM LITHIUM BATTERIES**

1.0 INTRODUCTION

The Electrochem Commercial Power division of Greatbatch Ltd. manufactures a wide variety of lithium batteries for use in military, oil exploration, oceanographic and other demanding commercial applications. The specific cell chemistries manufactured by Electrochem are summarized in Table I.

TABLE I

<u>Product Designation</u>	<u>Chemistry</u>	<u>Open-circuit Voltage (V)</u>	<u>Operating Temp Range (°C)</u>		
QTC	SOCl ₂	3.6	-40	to	85
LowRate100	SOCl ₂	3.6	-40	to	85
BCX85	SOCl ₂ /BrCl	3.9	-55	to	72
CSC93	SO ₂ Cl ₂ /Cl ₂	3.9	-32	to	93
PMX150/165	SO ₂ Cl ₂ /Cl ₂	3.9	-40	to	150/165
LowRate150 & MR150/165	SOCl ₂	3.6	-40	to	150/165
MWD150	SOCl ₂	3.6	0	to	150
LowRate & MR 180	SOCl ₂	3.6	+50	to	180
LowRate & MR 200	SOCl ₂	3.6	+70	to	200

The success of these systems is partially due to the fact that they contain more energy per unit weight than conventional batteries. However, the same properties which result in a high energy density also contribute to potential hazards if the energy is released at a fast, uncontrolled rate. With proper use and handling, these cells have demonstrated an excellent safety record. The cells produced by Electrochem are being used successfully by NASA and in other applications where safety and reliability is of utmost importance.

Because of the recognition of hazards associated with high energy density systems, safety has been incorporated into the design and manufacture of Electrochem lithium cells and batteries. For example, all commercial cells utilizing spirally wound electrodes are internally fused to protect the user against the hazards associated with short circuits. While we have designed our

cells and battery packs to be tolerant to adverse conditions, these very active chemical systems have limitations. Certain hazards are associated with exposure to heat and its subsequent effects on sealed cells. These hazards include possible battery venting, explosion and/or fires. The initial source of heat can be external (fire, soldering iron) or internal, such as heating caused by short circuit, forced over discharge, charging conditions or excessive mechanical abuse.

Specifically, mechanical abuse in the form of excessive shock or vibration can result in case deformation, crushing, and damage to the electrodes and/or separator material.

Most primary lithium cells have a warning printed on their label that cautions against the following conditions:

- Short-circuit
- Charging
- Forced over discharge
- Excessive heating or incineration
- Crush, puncture or disassembly

Not guarding against these conditions may result in a hot cell or battery pack that could either vent or explode. With Electrochem cells, the ensuing hazards associated with a hot cell, typically do not occur the instant the cell is abused. Rather, the cell heats up over a period of time and subsequently vents or explodes when its critical temperature is reached. The rate of heating is proportional to the extent of the abusive condition. For example, if a charging current is limited to the leakage current through a blocking diode, no heat will be generated. However, a 3A charge will cause a cell to heat to its critical temperature over a period of 8-10 minutes (depending on the size of the cell and the ambient temperature). Our cells are designed to operate over the temperature range listed in Table I. The critical temperature (as measured on the cell case) for the cells rated for 85 to 100 C is in the range of 125°C to 150°C. The critical temperature for the cells rated for 150 to 165 C is 165-180°C. The critical temperature for the cells rated for 180 C is 190-200°C, and the critical temperature for the cells rated for 200 C is 210-215°C.

One condition that could lead to a sudden explosion is severe structural deformation of the case or internal components due to excessive mechanical abuse.

2.0 SAFE HANDLING GUIDELINES

The intent of this section is to provide lithium battery users with guidelines necessary for safe handling of cells under normal manufacturing and use conditions. This document will address three principle areas:

- 1) Receiving inspection and subsequent storage of cells.
- 2) Handling procedures during product assembly.
- 3) Packaging for shipment.

2.1 RECEIVING INSPECTION AND STORAGE OF CELLS

In general, the conditions that cause damage to cells and jeopardize the safety of personnel are summarized on the label of each cell. These conditions include:

- Short circuit
- Charging
- Forced over discharging
- Excessive heating or incineration
- Crush, puncture or disassembly
- Rough handling or excessive shock and vibration

The most frequent forms of cell abuse can be easily identified and controlled in the workplace. It is our experience that inadvertent short circuits are the largest single cause of field failures. In addition, random short-circuiting is a common problem in receiving inspection, since cells are handled frequently at this stage.

All high rate Electrochem cells are internally protected against the hazards associated with short circuits. This is accomplished by incorporating a fast acting fuse under the terminal cap. While the fused cells will neither heat, vent, nor explode under a direct short circuit condition, they will be rendered useless (zero volts). However, cells subjected to high current discharge as may be caused by an intermediate short (a current limited to just below the fuse value) could overheat resulting in a venting situation. This is especially true if the cells are in an insulating environment. Therefore, shorting cells should be avoided.

Problems associated with shorting as well as other hazardous conditions can be greatly reduced by observing the following guidelines:

- Cover all metal work surfaces with an insulating material.
- The work area should be clean and free of sharp objects that could puncture the insulating sleeve on each cell.
- Never remove the terminal cap, shrink-wrap or protective potting from a cell or battery pack.
- All personnel handling cells should remove jewelry items such as rings, wristwatches, pendants, etc., that could come in contact with the battery terminals.
- If cells are removed from their original packages for inspection, they should be neatly arranged to preclude shorting. Do not stack or scatter the cells. They should be placed in plastic carrying trays with individual compartments for each cell.
- Cells should be transported in plastic trays set on pushcarts. This will reduce the chances of cells being dropped on the floor causing shorting or other physical damage.
- All inspection tools (including calipers, rulers, etc.) should be made from, or covered with, a non-conductive material such as plastic or kapton.
- Cells should be inspected for physical damage, possibly caused by dropping the cell. Cells with dented cases or terminal caps should be inspected for electrolyte leakage. If any is noted, the cell should be disposed of in the proper manner. (See Section 4.0 for handling procedures of leaking or vented cells.)
- Measure the open-circuit-voltage (OCV) of the cell. The nominal OCV for each cell chemistry is printed on each cell label. Note: An open circuit voltage of 0.0 volts is indicative of a blown fuse.
- After a cell has been inspected it should be returned to its original container.
- If leads or solder tabs need to be shortened, only cut one lead at a time.

Cutting both leads at the same time will short-circuit the cell.

- The cells must never be disassembled. In addition, never attempt to repair a blown fuse. This must only be replaced at the factory.

2.2 CELL STORAGE

Storage of hazardous materials is generally regulated by Federal, State and local codes. These codes may regulate the location and amount of material that may be stored in a designated area. In addition these general guidelines should be followed:

- Cells should be stored in their original containers.
- Store the cells in a well-ventilated, dry area. The temperature should be as cool as possible to maximize shelf life.
- Store the cells in an isolated area, away from combustible materials. Store depleted cells in an area separate from fresh cells.
- Any lithium battery storage area should have immediate access to a class D fire extinguisher and respirators.
- Never stack heavy objects on top of boxes containing lithium batteries to preclude crushing or puncturing the cell case. Such severe damage can lead to internal short circuits resulting in a cell venting or explosion.
- Do not allow excessive quantities of cells to accumulate in any storage area.

2.3 HANDLING PROCEDURES DURING PRODUCT ASSEMBLY

The guidelines defined in sections 2.1 and 2.2 should be incorporated in all areas of the facility. Additional precautionary measures should be observed in production areas to avoid more serious problems associated with heat, especially around soldering equipment or during routine performance testing at elevated temperatures. Safety glasses should be worn at all times.

One way to limit the potential for incidents that could occur in a manufacturing area is to reduce exposure to the cells. This can be accomplished by utilizing "just in time" concepts when delivering cells to the production area. Deliver

only the required amount of cells (on a daily basis) to production. Keep additional cells in the stock area.

- Written work instructions should be generated for each manufacturing procedure.
- Transport cells in plastic trays set on push carts. This will reduce the chances of cells being dropped on the floor causing shorting or other damage.
- Heat sensitive sheets can be placed over the plastic trays. Hot cells, indicative of a potential problem, are easily identified using this technique.
- Never touch a cell case directly with a hot soldering iron. Heat sinks should be used when soldering to the tabs and contact with the solder tabs should be limited to a few seconds.
- Exercise caution when handling cells around solder pots. If leads need to be tinned do only one at a time. Also, guards should be in place to prevent cells from falling into solder pots.
- All high rate Electrochem cells incorporate a fuse under the terminal cap. A wave soldering operation will blow the fuse rendering the cell useless. Hand solder all cells and battery packs equipped with fuses.
- Cells should not be forced into battery holders or other types of housings. This could deform the bottom of the case causing an internal short circuit. Furthermore, the terminal cap could be crushed putting pressure on the glass-to-metal seal. This could result in a cell venting. Check for proper fit before inserting the cells into any type of housing.
- For the reasons stated above, excessive force should never be used to free a cell or battery lodged inside a housing.
- Cells and/or batteries, should not be exposed to high voltage AC sources or other DC power supplies. This could result in subjecting the cells to charging or forced-discharging currents.
- All ovens or environmental chambers used for testing cells or batteries should be equipped with an over temperature controller to protect against

excessive heat.

2.4 PACKAGING FOR SHIPMENT

U. S. domestic transportation of hazardous materials is regulated by the Department of Transportation (DOT) through *Title 49 Code of Regulation (49 CFR)*, part 173.185. Internationally, air transportation is regulated by the *International Air Transport Association (IATA) Dangerous Goods Regulations (DGR)*. Other countries may have regulations pertaining to hazardous materials (dangerous goods) as well when shipped in, from, or to countries outside of the U.S. The information contained in this section is a summary of requirements in place on October 5, 2005.

Pursuant to 49 CFR 173.185, all shipments of hazardous materials in the U.S. must comply with packaging regulations which are based on recommendations made by the United Nations. The packaging regulations require "performance oriented" packaging, which means that a package must pass the following tests designed to demonstrate it's integrity:

- Drop test
- Vibration
- Leak proof test (where applicable)
- Internal pressure (hydraulic) test (where applicable)
- Stacking test

These tests are usually performed by authorized independent testing organizations or a packaging supplier. Once a packaging system has been certified to meeting the tests, the packaging is stamped with a UN marking. UN marked packaging may only be used to transport hazardous materials that have been used in the packaging tests.

Lithium cells and batteries are classified as a hazardous material in the U.S. unless the specific cell or battery meets an exemption in 49 CFR 173.185. When shipping lithium cells and batteries in the U.S., the determination as to whether or not an exemption applies first depends on the cell or battery classification and the lithium content in the cell or battery. The DOT recognizes three classifications for lithium batteries, solid cathode, liquid cathode, and lithium ion. Furthermore, lithium cells and batteries shipped in or with equipment are addressed separately in the regulations.

Lithium cells and batteries are determined to be “not restricted” if they meet the requirements of 49 CFR 173.185(e). In summary, lithium cells and batteries may be shipped as “not restricted” if the specific cell design and packaging requirements in the regulations are met, and the cell or battery has a lithium content below the thresholds listed below. Lithium content means the mass of lithium in the anode of a lithium metal or lithium alloy cell.

	Liquid Cathode	Solid Cathode	Lithium Ion
Cell	<0.5g Li	<1.0 g Li	<1.5 g Li*
Battery	<1.0 g Li	<2.0 g Li	< 8.0 g Li*

*"Equivalent Lithium Content" = 0.3 * rated capacity in ampere-hours

Please note that in the U.S. lithium cells and batteries are forbidden for transport upon passenger aircraft and all packaging for “not-restricted” lithium cells and batteries must contain a labeling as stated in 49 CFR 173.185.

Lithium cells and batteries that exceed the above lithium content limitations may also be non-restricted when transported in the U.S. if the requirements of 173.185(c) are met and a cell contains less than 5.0 g of lithium content, or a battery contains less than 25.0 g or less of lithium content. Each cell or battery using the 173.185(c) exemption must also be of the type proven to be non-dangerous by testing in accordance with tests in the *UN Manual of Tests and Criteria* for lithium batteries. Packaging and labeling requirements in 173.185(c) must be met as well.

Lithium cells and batteries which exceed the lithium content limitations in 173.185(b) may be transported as a hazardous material, Class 9, if the requirements of 173.185(e) are met. Class 9 requirements include UN Performance-Oriented packaging, labeling, weight restrictions, and that the lithium cells and batteries must have completed the UN Manual of Tests and Criteria for lithium batteries.

When transporting lithium cells and batteries by air, IATA DGR Special Provisions A45, A88, and A99 require all lithium cells and batteries to meet the requirements of the *UN Manual of Tests and Criteria, Part III, Subsection 38.3*. Greatbatch can provide a Transport Certificate acknowledging that a specific lithium cell or battery has completed the testing requirements and can be transported by air if no changes are made to the original configuration of the cell or pack as manufactured and transported from a Greatbatch facility. Customers and value added distributors must also test lithium cells and battery packs to the above requirements if changes are

made to the original configuration of the lithium cell or battery.

Lithium cells and batteries “contained in equipment” or “packed with equipment” are regulated as well when transported by aircraft and the lithium cells and batteries have not been determined to be “not-restricted” per IATA DGR Special Provision A45. Lithium cells and batteries “contained in equipment” or “packed with equipment” are shipped as a Class 9 material. Class 9 requirements include UN Performance-Oriented packaging, labeling, weight restrictions, and that the lithium cells and batteries must have completed the *UN Manual of Tests and Criteria* for lithium batteries.

The U.S. DOT requires shippers of hazardous materials to, from, and within the U.S., such as manufacturers and distributors, to be in compliance with the Emergency Response Communication Standard per Title 49, Part 171 et. al. This regulation requires that the shipper of hazardous materials use the proper shipping name, have a 24-hour emergency response information system and provide emergency response mitigation information with each shipment. U.S. DOT also requires all shippers of hazardous materials complete training before the first shipment and every three years thereafter, as required under 49 CFR 172.704. The IATA DGR requires training every 2 years.

There are additional regulations for shipping lithium cells and batteries that do not fall into the categories listed above. Lithium batteries, for disposal, may be transported to a permitted storage facility and/or disposal site by motor vehicle only in the U.S. if the requirements of 173.185(h) are met. Prototype lithium cells and batteries which need to be transported before the *UN Manual of Tests and Criteria* requirements have been met, have additional packaging and labeling requirements, and may require authorization by the country where the prototypes will be transported to, from, and within.

3.0 BATTERY PACK ASSEMBLY

While Electrochem cells possess a high power and energy density, many applications require even greater voltage, current or capacity than a single cell can provide. The solution can be a battery pack of series and/or parallel configuration. The purpose of this document is to provide a qualified user with guidelines for the selection, design and fabrication of lithium cells into battery

packs.

The design of a battery can either enhance or worsen the safety characteristics of individual cells. For example, a series configuration may increase the potential for subjecting cells to forced over discharge conditions. Parallel strings can lead to charging currents. Battery packs should be designed to avoid conditions leading to short-circuiting, forced over discharging, charging, or overheating. This can be accomplished through proper design and use of protective devices such as fuses, thermal switches, heat sinks and diodes as required.

3.1 CELL SELECTION

Designers should choose batteries with the lowest power output needed to meet the application requirements. In addition to this, the following basic rules must be observed:

- Always use the same cell chemistry in a battery pack. Do not mix Li/SO₂, Li/SOCl₂, Li/SO₂Cl₂, , Li/MnO₂ or any other type of cell in a pack design.
- Always use the same cell types in series or parallel connections.
- Cells fabricated into batteries should be of the same age (lot code) and history.
- Primary and secondary cells must not be mixed together in a battery pack.
- Partially discharged cells must not be mixed with fresh cells in a battery pack.

3.2 BATTERY PACK DESIGN

It is strongly recommended that batteries be built by the cell manufacturer or an authorized value-added-reseller. If this is not practical, the cell manufacturer should be consulted so that the most appropriate protective devices are integrated into the battery design and assembly.

Battery packs must be designed to avoid conditions leading to low level current leakage paths or direct short-circuiting. This is accomplished by choosing the proper insulating materials for use in the pack construction.

The materials chosen must not only have a high resistance to leakage current, but must also be a good dielectric. The insulation resistance is usually expressed in M and the dielectric strength is measured in terms of volts/mil thickness of material. It should be noted that the insulation resistance of materials decreases rapidly with increased temperature. Also, absorbed moisture reduces the insulation resistance, and moisture and humidity could have a large effect on the surface electrical leakage of a battery.

The materials used to protect individual cells were chosen because of their high dielectric strength and temperature tolerance. The dielectric strength of the shrink-wrap used on the cells is as follows:

<u>Materials</u>	<u>Nominal thickness</u>	<u>Dielectric strength</u>
PVC	4-6 mils	1083 volts/mil
Kynar	8-10 mils	800-1000 volts / mil
FEP	8-10 mils	2000 volts / mil

Materials with similar properties should be used in the construction of battery packs.

In certain instances, the materials chosen must also display good abrasion or puncture resistance in addition to having good electrical properties. For example, if circuit boards are mounted directly on top of the battery, cell terminations must be isolated from traces on the underside of the board. Solder points can have sharp protrusions that can puncture thin materials such as Kapton tape. Thick, puncture resistant insulation must be used in these areas. Designers should consider surface mount technology to eliminate traces and through holes on the underside of the boards. Following are the minimum requirements for protecting battery packs from specific abusive conditions:

- In the fabrication of battery packs where cells or batteries are connected in parallel, diode protection is required to eliminate the exposure of cells to charging currents. Figure 1 shows the proper placement of diodes in a battery pack to eliminate charging currents from parallel battery strings.

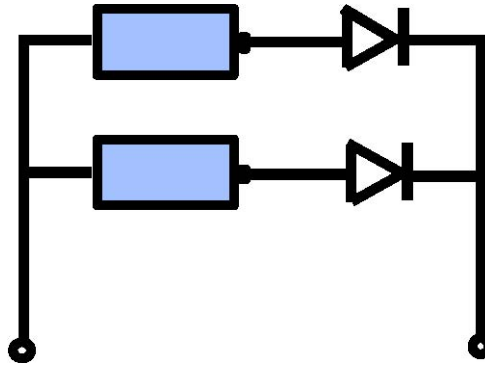

Figure1ChargeProtection

There are four factors one must consider when selecting a diode:

- Forward Current (I_F) - This is the maximum rated current which the diode can pass. The I_F must be greater than the expected discharge current of the battery.
- Reverse Current (I_R) - This is the amount of current the diode will pass in the reverse direction. The diode selected should have an I_R less than 0.1mA. This will alleviate the effects charging currents have on both cell safety and performance.
- Reverse Voltage or Breakdown Voltage (V_R) - This is the amount of reverse voltage which can be applied to the diode before breakdown occurs. V_R should be selected to be greater than the OCV of any one of the battery strings.
- Forward Voltage Drop (V_F) - This is the amount of voltage lost due to the use of a diode. If a diode is placed in series with a 3.0V cell the usable voltage will be 3.0-V_F. Two types of diodes are available. Silicon diodes have a V_F of 0.7 volts. Germanium or schottkey diodes have a V_F of 0.3 volts.

It is particularly important to use series diodes in this configuration where there is another power source (e.g. where the cell or pack is used as a back-up to main power). Precautions must be taken to avoid charging of the battery from the external source.

Diodes can also be used to protect cells in a series string from forced over discharge conditions. Figure 2 shows the proper placement of a diode to eliminate forced over discharge conditions.

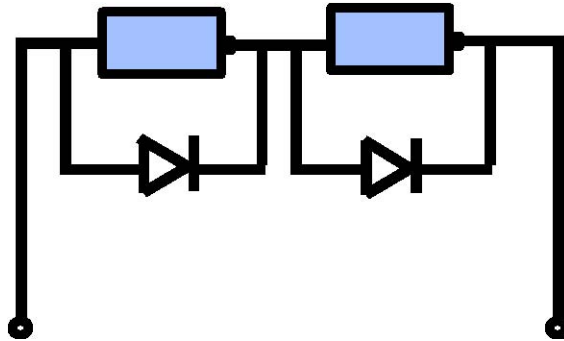

Figure 2 Reversal Protection

Each cell in a series string should be equipped with a diode connected in parallel. Under normal operation, the current will flow through the cell because the diode is reversed biased. If a given cell in the series string is prematurely depleted, its shunt diode will become forward biased and the current will pass through it. This is a simple yet effective way to minimize hazards associated with forced over discharge conditions. It is important to pick diodes with a low I_R for this type of use, otherwise, the cells will be prematurely discharged through the diode. Additional protective measures that should be considered in battery pack design are:

- In-line fuses (series) should be fitted external to the battery such that they may be replaced if the battery is inadvertently short-circuited.
- A limiting resistor can also be placed in series with a series diode. This will limit the current to the lowest practical value consistent with the application.
- Thermal cutoff (TCO) or resettable polymeric, positive temperature coefficient (PTC) resistors can be used to keep the pack from exceeding the safe temperature limits of the cells.
- Both the surrounding thermal environment and the heat output of a

battery pack during operation should be evaluated. The heat generation of the cells should be calculated.

- For larger packs, or for batteries run at high rates, additional thermal management must be considered. For example copper or aluminum heat sinks can be incorporated into the pack design to effectively conduct excessive heat away from the cells during discharge.
- Cells connected in series should not contain a center voltage tap. This will eliminate the possibility of cells being unequally discharged.
- Batteries should not be encapsulated without first consulting the manufacturer.
- The bottom of most high temperature cells will swell as a normal result of high temperature discharge. The cell compartment must be designed with adequate inter-cell spacing to accommodate this expansion.
- Battery pack construction should take into account the need for cell vents to function (where applicable). There should be an unrestricted escape path for the fumes such that pressure does not build up in the battery pack. A vent mechanism should also be incorporated in rigid housings to avoid rupture of the outer battery case.
- Shock and vibration requirements must be considered in the design of any battery pack. All cells must be protected from excessive shock and vibration.

3.3 BATTERY FABRICATION

It is essential that engineering drawings and work instructions are completed prior to the initial pack construction. The general handling procedures outlined in this document should also be observed. Also, safety procedures should be in place to cover any hazards that may arise while assembling and handling battery packs.

Personnel assembling battery packs should comply with the following recommendations:

- High Impact Safety glasses (Z87 +) must be worn at all times. All jewelry

should be removed so that the cell could not be inadvertently shorted.

- Cells received from the factory should remain in their original containers until they are to be assembled into battery packs.
- Cells should not be placed on electrically conductive surfaces. All work surfaces should be constructed with non-conductive materials. Do not use anti-static or static dissipative packaging
- Do not solder directly to the cell case. Only solder to the free end of solder tabs welded to the case.
- Solder tabs that extend from the case and terminal cap should be insulated.
- Avoid cutting or piercing the insulating shrink-wrap on the cells.
- Loose wires should not be stripped until it is time to install a connector. If no connector is used, wire ends should be insulated.
- Should wire trimming be necessary, only cut one wire at a time.
- All packs should be labeled with the appropriate warnings as they appear on the cell label.
- Certain potting compounds are exothermic (release heat) when they set. It is important that the maximum temperature of the cell is not exceeded during the potting process.
- Under no circumstances should the terminal cap and fuse assembly be removed from a cell.

4.0 HANDLING UNDER ADVERSE CONDITIONS

Abusive conditions discussed in previous sections must be avoided to ensure safe handling of our cells. However, if mistakes are made in battery pack design or in cell handling that result in a cell venting or exploding, the user should be equipped to cope with such emergencies. Our intent is to provide any handler with knowledge which is needed for safe handling of cells that

have been subjected to these extreme conditions. This document will address four principle areas:

- 1) Hot cells
- 2) Cells that have leaked or vented
- 3) Cells that have exploded
- 4) Fires involving lithium batteries

4.1 PROCEDURES FOR HANDLING A HOT CELL

As soon as it has been determined that a hot cell situation exists, the first action is to completely evacuate all personnel from the area. The area should be secured such that no unnecessary persons enter.

If the situation allows, before leaving, the person who first identified the hot cell should quickly determine if an external short-circuit is present and remove it as quickly as possible. After the short has been removed, the cell should start to cool. However the area should remain evacuated until the cell has cooled to room temperature and has been removed from the area. The temperature of the cell should be monitored periodically with a remote sensing device such as an infrared temperature sensor.

If the hot cell situation persists, then the following course of action can be considered.

4.1.1 Minimum Equipment Required

- Infrared temperature probe
- Safety glasses
- Helmet with high impact resistant face shield
- Non-conductive extended pliers
- Body, arm and hand protection.

4.1.2 Procedure

- As soon as a hot cell is detected, completely evacuate the area of all personnel.
- Periodically monitor the temperature of the cell with the remote probe

for the first two hours or until one of the three following situations occurs:

- the cell starts to cool;
 - the cell vents; or
 - the cell explodes.
- If the cell starts to cool, monitor its temperature once an hour until it returns to ambient temperature.
 - If remote temperature sensing equipment is not available, do not handle the cell for a period of 24 hours.
 - Remove the cell from the work area once it has cooled and return to normal operations.
 - Dispose of the cell in accordance with local, state and federal hazardous waste regulations.
 - Procedures for handling cells that continue to heat and, resultantly, either vent or explode will be addressed in Sections 4.2 and 4.3.

4.2 PROCEDURE FOR HANDLING CELLS THAT HAVE VENTED

All Electrochem lithium batteries are hermetically sealed in a 304L stainless steel case. A glass-to-metal seal is used as an electrical feed-through for the positive terminal. Under normal operating conditions, a cell will not leak or vent. However, cell leakage or venting can occur if the cell is overheated or the glass seal is compromised by excessive physical abuse.

The severity of a vent condition can range from a slight leak around the glass-to-metal seal to a violent expulsion of material through the glass seal. In instances where the cell is unrestrained, this can result in the cell becoming a projectile.

The electrolyte contained within the lithium cells can cause severe irritation to the respiratory tract, eyes and skin. In addition, violent cell venting could result in a room full of corrosive vapors summarized in Table II.

TABLE II

<u>Cell Chemistry</u>	<u>Vent Products</u>	<u>Properties</u>
QTC/QTCII, BCX85 MWD, VHT And all MR and low rate series	SOCl ₂ Br ₂ , Cl ₂ , HCl	Non-flammable, eye irritation Corrosive, inhalation hazard, causes chemical burns to skin. Negligible fire hazard
CSC and PMX	SO ₂ Cl ₂ Cl ₂ , HCl H ₂ SO ₃ SO ₂	Non-flammable, eye irritation corrosive, inhalation hazard, causes chemical burns to skin. Negligible fire hazard

All precautions should be taken to limit exposure to the electrolyte vapor. Product safety data sheets are attached in appendix A for our particular cell chemistries.

4.2.1 Minimum Equipment Required

- A Class D fire extinguisher
- Eye protection or face shield
- Respirator suitable for chlorine, HCl and SO₂
- Neoprene rubber gloves
- Lab coat or chemically resistant apron
- Bicarbonate of soda (baking soda), calcium oxide (lime) -or-acid spill clean up kit
- Vermiculite, 3M Power Sorb (universal absorbent material), Speedy-Dry (clay absorbent)
- Individual thick plastic bags with sealing mechanism

4.2.2 Procedure

- Should electrolyte leak from a cell the following actions should be taken:
- Evacuate personnel from all areas which are affected by the vapors.

- Ventilation should be initiated and continued until after the cell is removed from the area and the pungent odor is no longer detectable.
- If the cell vented as a result of excessive heating, it must be allowed to cool to ambient temperature before handling. (Refer to hot cell procedure in section 4.1)
- Put on lab coat, rubber gloves, high impact safety glasses and respirator. Remove the cell to a well-ventilated area.
- Place each leaking cell in a separate, sealable plastic bag. Eliminate excess air and seal the bag.
- Place one cup of vermiculite or other absorbent material in a second bag along with the first bag. Eliminate excess air and seal.
- Place the double-bagged cell in a third bag containing approximately one cup of lime or baking soda. Seal the bag.
- Absorb and/or neutralize spilled electrolyte with an absorbent material or baking soda.
- Sweep contaminated baking soda or absorbent material into a sealable plastic bag for disposal.
- Clean the area with copious amounts of water.
- Dispose of the vented cell and contaminated absorbent material in accordance with local, state and federal hazardous waste disposal regulations.

4.2.3 First Aid Procedures in Case of Contact with Electrolyte

- | | | |
|------|----|---|
| EYES | -- | Immediately flush eyes with a direct stream of water for at least 15 minutes while forcibly holding eyelids apart to ensure complete irrigation of all eye and lid tissue. GET IMMEDIATE MEDICAL ATTENTION. |
| SKIN | -- | Flush with cool water or get under a shower, remove contaminated garments. Continue to flush for at least 15 minutes. |

Get medical attention, if necessary.

INHALATION -- Move to fresh air. If breathing is difficult have trained person administer oxygen. If respiration stops, give mouth-to-mouth resuscitation. **GET MEDICAL ATTENTION IMMEDIATELY.**

4.3 PROCEDURE FOR CELLS THAT HAVE EXPLODED

Electrochem cells have the highest energy density of any commercial lithium battery on the market. It is the combination of high voltage and capacity, coupled with light weight, that makes our cells attractive for many specialty applications. However, when a large amount of energy is contained in a small package, the results can be energetic if the system is abused.

It is unlikely that any lithium battery would explode. These events are rare and are usually the result of an abusive condition that raises the cell's temperature above its critical point. However, in the event of a lithium battery explosion, a room will fill quickly with dense white smoke which can cause severe irritation to the respiratory tract, eyes and skin. All precautions must be taken to limit exposure to these fumes.

4.3.1 Minimum Equipment Required

- A Class D fire extinguisher
- ABC Class fire extinguisher (for possible secondary fires only)
- Respirator suitable for chlorine, HCl and SO₂ or air pack
- Eye protection or face shield
- Rubber gloves, lab coat or chemically resistant apron
- Bicarbonate of soda or calcium oxide (lime) -or- acid spill clean up kit (J.T. Baker Co.)
- Vermiculite, 3M Power Sorb (universal absorbent material), Speedy-Dry (clay absorbent)
- Individual thick plastic bags with sealing mechanism, glass jars.

4.3.2 Procedure

- Should a cell explode the following actions should be taken:
- Evacuate personnel from all areas which are affected by the smoke.

- Ventilation should be initiated and continued until after the cell is removed from the area and the pungent odor is no longer detectable.
- Although this scenario is unlikely, should there be a fire resulting from an explosion, methods for dealing with this contingency are addressed in Section 4.4.
- The exploded cell may be hot. It must be allowed to cool to ambient temperature before handling. (See hot cell procedures)
- Put on a lab coat, rubber gloves, safety glasses and respirator.
- If a cell explodes the surrounding area may be covered with black carbonaceous material along with metal parts from the cell. Cover the black carbonaceous material with a 50/50 mixture of baking soda (or lime) with vermiculite or other universal absorbent material.
- Sweep the contaminated baking soda/vermiculite mixture into a sealable plastic bag. Gather in such a way as to avoid excessive dust. Metal parts can also be included in this container. Note: Metal fragments should never be packaged with live cells. This could cause the cell to become shorted.
- Seal the plastic bags in a glass jar and dispose of contents in accordance with local, state and federal hazardous waste disposal regulations.
- Clean the area with copious amounts of a baking soda/water solution. Follow with soapy water.

4.3.3 First Aid Procedures in Case of Contact with electrolyte

EYES	--	Immediately flush eyes with a direct stream of water for at least 15 minutes while forcibly holding eyelids apart to ensure complete irrigation of all eye and lid tissue. GET IMMEDIATE MEDICAL ATTENTION.
SKIN	--	Flush with cool water or get under a shower, remove contaminated garments. Continue to flush

for at least 15 minutes. Get medical attention, if necessary.

INHALATION -- Move to fresh air. If breathing is difficult, have trained person administer oxygen. If respiration stops, give mouth-to mouth resuscitation. GET MEDICAL ATTENTION IMMEDIATELY.

4.4 FIRES INVOLVING LITHIUM BATTERIES

All metals will burn under proper conditions depending on such factors as: physical form, oxidizing atmosphere, and severity of the ignition source. Alkali metals such as lithium will burn in a normal atmosphere. It should also be noted that lithium reacts explosively with water to form hydrogen. The presence of minute amounts of water may ignite the material and the hydrogen gas.

Once ignited, a metal fire is difficult to extinguish with ordinary means. This is due in part to the intense heat produced by the burning metal, the temperature of which may reach as high as 3000°F. Furthermore, lithium metal can react violently with many common fire-extinguishing materials, such as water and carbon dioxide.

Specially formulated extinguishing agents are required to control or put out a lithium fire. In particular, a graphite-based extinguisher (Lith-x) should be used. These agents function generally by forming a layer or crust of material over the burning metal. Lith-x, which is a popularly used graphite based agent, may be applied from an extinguisher or by shoveling the loose powder onto the fire.

In the event of a lithium fire, a room could become filled with dense white smoke, mostly comprised of lithium oxide and/or other metal oxides. This condition could cause severe irritation to the respiratory tract, eyes and skin. All precautions must be taken to limit exposure to these fumes.

It should also be noted that the following procedures are only applicable to fires involving a single cell. Larger fires involving multiple cells should be handled by professionally trained people.

In addition, it is Electrochem's practice to use an extinguishing agent best suited to quench the bulk of the fuel available. For example, if a single cell were

to start burning during a destructive analysis a Lith-x extinguisher would be used to quench the fire. If other combustibles catch fire as result of the lithium battery then use the appropriate extinguishing agent to douse these secondary fires. A BC type or CO₂ extinguisher could be used on solvent/electrical fires or a general purpose ABC type could be used on all combustible materials. It is important to address each type of fire with the appropriate extinguisher.

DO NOT USE ABC OR CO₂ TYPE EXTINGUISHERS ON LITHIUM METAL FIRES.

4.4.1 Minimum Equipment Required

- A Class D fire extinguisher (Lith-x)
- An ABC class fire extinguisher (for possible secondary fires only)
- Self-contained breathing apparatus
- Full fire-fighting protective clothing
- Heat resistant gloves
- Goggles or safety glasses
- Non-conductive extended pliers
- Shovel, mineral oil

4.4.2 Procedure

4.4.2.1 Initial Response

- In order to respond adequately to any emergency situation a primary response team should be established. After training in safety and handling procedures, along with first aid and fire fighting methods, the primary response team will be able to respond to situations involving lithium batteries.
- When a fire is detected the first action is to completely evacuate all personnel from the area and sound the fire alarm immediately.
- The primary response team is paged to the area where the fire is located. The team is informed of any pertinent information regarding the situation by the person who reported the fire.
- Quarantine the area. Ventilation should be initiated and continued until the burning material is removed from the area and the pungent odor is

no longer detectable.

- Two members of the team will then enter the area with the appropriate fire-fighting and safety equipment.

NOTE: Lithium melts at 180°C. It becomes highly reactive and when ignited, lithium fires can throw off molten lithium metal particles. Furthermore, cells adjacent to any burning material could overheat causing a violent explosion. Fire-fighting teams must be made aware of any hazardous materials in the vicinity of the fire.

- Completely bury the burning material with Lith-x to extinguish the fire. Never leave the fire unattended because it may reignite.
- If necessary, attend to any secondary fires with the appropriate extinguishing agent.
- After all material has apparently burned and cooled, carefully turn over the remaining residue and be prepared to extinguish, should re-ignition occur.
- Carefully place the residue in a steel drum using a long-handled shovel, and cover with excess Lith-x. The residue may contain unreacted lithium, therefore limit exposure to moisture. This can be accomplished by covering the residue with mineral oil.

4.4.2.2 Clean-up

- A lab coat, rubber gloves, safety glasses or goggles and respirator should be worn during cleanup.
- The surrounding area may be covered with black carbonaceous material along with metal parts from the cell. Cover the black carbonaceous material with a 50/50 mixture of baking soda (or lime) with vermiculite. A wet sweeping compound may also be used to avoid dust. Nonetheless, gather the material in such a way as to avoid excessive dust.
- Sweep the contaminated baking soda/vermiculite mixture into a sealable plastic bag. Metal parts can also be included in this container.

- Seal the plastic bags in a glass jar or other suitable container.
- Clean the area with copious amounts of a baking soda/water solution. Follow with soapy water.
- Dispose of all materials in accordance with local, state and federal hazardous waste disposal regulations.

4.4.2.3 First Aid Procedures in Case of Contact with Electrolyte and Molten Lithium Metal:

EYES	--	Immediately flush eyes with a direct stream of water for at least 15 minutes while forcibly holding eyelids apart to ensure complete irrigation of all eye and lid tissue. GET IMMEDIATE MEDICAL ATTENTION.
SKIN	--	Flush with cool water or get under a shower, remove contaminated garments. Continue to flush for at least 15 minutes. Get medical attention, if necessary. IF MOLTEN LITHIUM METAL IS EMBEDDED IN THE SKIN AND CANNOT BE REMOVED, COVER WITH MINERAL OIL AND GET MEDICAL ATTENTION IMMEDIATELY.
INHALATION	--	Move to fresh air. If breathing is difficult have trained person administer oxygen. If respiration stops, give mouth-to-mouth resuscitation. GET MEDICAL ATTENTION IMMEDIATELY.

4.5 Regulatory Considerations

Throughout this document, recommendations have been made to properly handle lithium cells and batteries. Recommendations have also been made on how to handle emergency situations. To aide the end user in these recommendations, certain regulatory standards and requirements are being listed to aide the individual user in establishing individual compliance. However, it is the responsibility of each end user to establish their own internal policies and procedures, and follow all federal, state, and local regulations.