

# 3B0076

High Rate DD Cell  
Lithium Bromine Chloride

## BCX85 Series

### Physical Characteristics

<b>Chemistry</b>	Bromine Chloride
<b>Construction</b>	Spiral
<b>Cell Size</b>	DD
<b>Length<sup>1</sup></b>	111.5 mm
<b>Diameter<sup>2</sup></b>	33.5 mm
<b>Cell Weight</b>	213.0 g
<b>Lithium Weight</b>	9.9 g
<b>Integrated Safety Fuse</b>	Yes

Cell Drawing

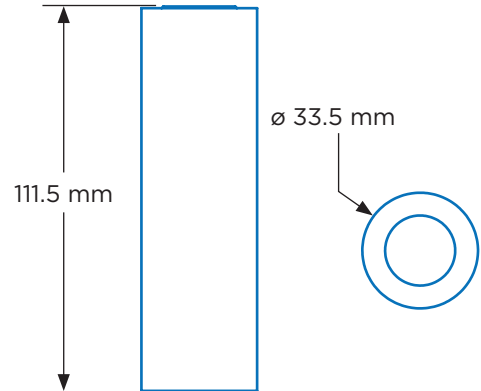

### Electrical Characteristics

<b>Cell Type</b>	Primary
<b>Open Circuit Voltage (25°C)</b>	3.9 V
<b>Nominal Capacity</b>	30 Ah
<b>Maximum Continuous Current</b>	3000 mA
<b>Operating Temperature</b>	-55°C to +85°C
<b>Self Discharge Rate</b>	<3% per year
<b>Storage Temperature</b>	≤ 25°C
<b>Discharge Condition</b>	350 mA, 23°C

Discharge Curve  
350 mA, 23°C

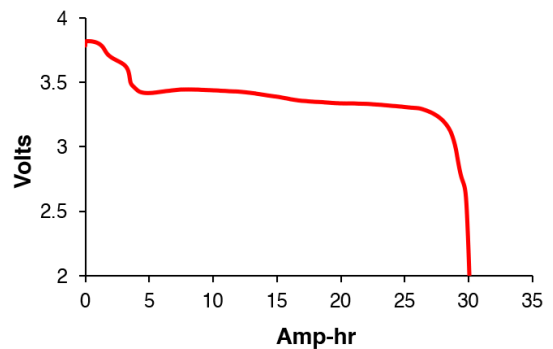

### Key Features

- Primary chemistry (non-rechargeable)
- High rate capability
- Advanced spiral-wound technology
- Stainless steel container
- Hermetic glass-to-metal sealing
- Restricted for transportation (Class 9)
- Custom terminations available

### Main Applications<sup>3</sup>

- Military communications
- Oceanographic buoys and gliders
- Tracking systems
- Sensor systems
- Pipeline inspection gauges
- Beacons, transponders and receivers
- Seismic surveying birds

NOTE: <sup>1</sup> The information on this datasheet is for marketing purposes only. Please consult with Electrochem for more information regarding how our cells will perform within your application. <sup>2</sup> The information in this document is subject to change without notice and does not constitute a warranty of performance. <sup>3</sup> This product and its external electrical contact materials are RoHS compliant. See our "RoHS Statement" for more information. <sup>4</sup> The length dimension was based off of a flat termination. The use of other terminations will impact overall cell length. <sup>5</sup> Diameter measurements include shrink when applicable. <sup>6</sup> The "Main Application" list does not include all potential applications, please consult Electrochem for your application needs.